



Part No.: L-1025RC



ATTENTION

OBSERVE PRECAUTIONS
FOR HANDLING
ELECTROSTATIC
DISCHARGE
SENSITIVE
DEVICES

➤ **Features**

- Single color
- High bright output
- Low power consumption
- High reliability and long life

➤ **Descriptions:**

- Dice material: AlGaInP
- Emitting Color:
Super Red
- Device Outline:
φ 10mm Round Type
- Lens Type:
Water Clear

➤ **Directivity:**

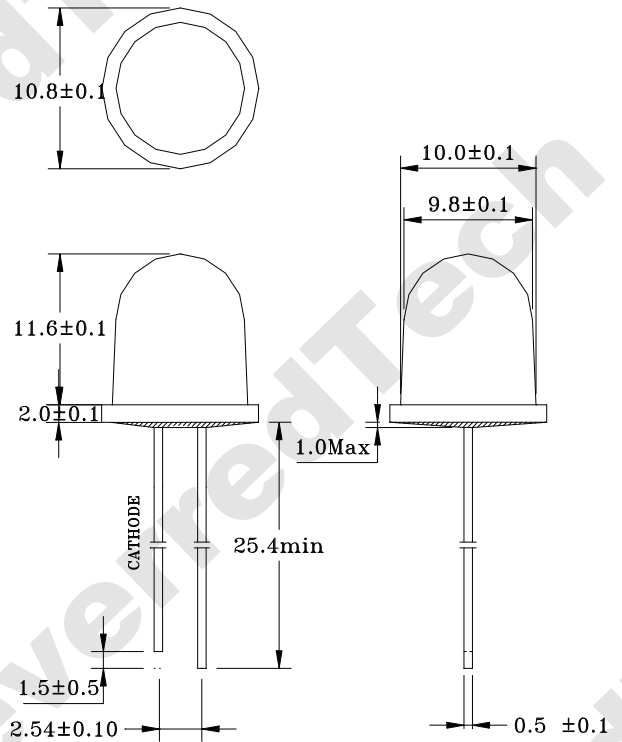

1. All dimensions are millimeters
2. Tolerance is +/-0.25mm unless otherwise noted

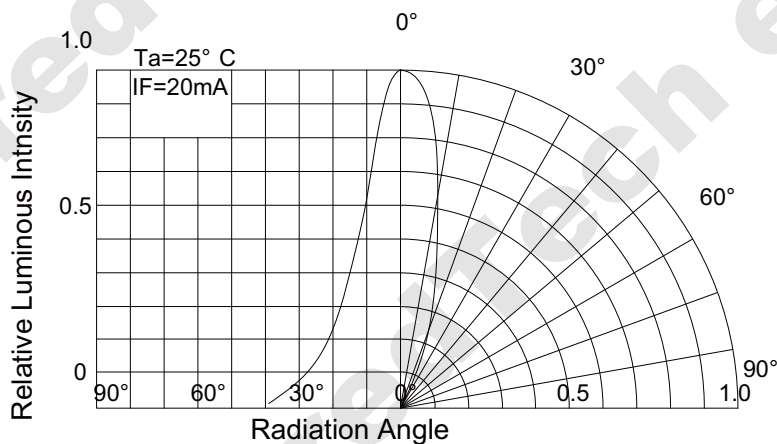



Part No.: L-1025RC

Absolute maximum ratings (Ta = 25°C)

Parameter	Symbol	Test Condition	Value		Unit
			Min.	Max.	
Reverse Voltage	V _R	I _R = 30 μA	5	--	V
Forward Current	I _F	----	----	30	mA
Power Dissipation	P _d	----	----	75	mW
Pulse Current	I _{peak}	Duty=0.1mS, 1kHz	----	100	mA
Operating Temperature	T _{opr}	----	-40	+85	°C
Storage Temperature	T _{str}	----	-40	+100	°C

Electrical and optical characteristics (Ta = 25°C)

Parameter	Symbol	Test Condition	Value			Unit
			Min.	Typ.	Max.	
Forward Voltage	V _F	I _F = 20mA		2.2		
Reverse Current	I _R	V _R = 5V	----	----	30	μA
Dominate Wavelength	λ _d	I _F = 20mA		629		
Peak Wavelength	λ _p	I _F = 20mA	----	635	---	nm
Spectral Line half-width	Δλ	I _F = 20mA	----	20	----	nm
Luminous Intensity	I _v	I _F = 20mA		3500		
Viewing Angle	2θ 1/2	I _F = 20mA	17		25	Deg.

Typical electrical/optical characteristic curves:

